

# 2 Post 2U Conversion Kit for Dell PowerEdge 2950

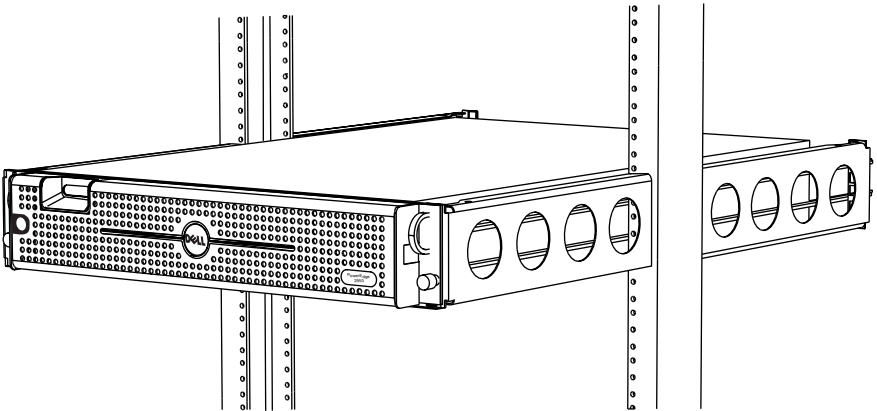

Installation Instructions  
Kit P/N: 2POST-2UKIT-2950

# 2POST-2UKIT-2950 Contents

---

## Kits Contents:

(4) 2U Conversion Brackets (13" Long)

## Alignment Hardware:

(4) Alignment Washers

(4) Truss Head Screws

## Rack Mount Hardware Kit:

(12) 12-24 x 1/2" Bolts

(8) 12-24 Cage Nuts

## Bracket Location

---

- Step 1.** Select the location of the Rack Mount equipment: 2U Rackmount equipment occupies 3.5" of rack space (six holes).
- Step 2.** Locate the mounting holes per the diagram below.

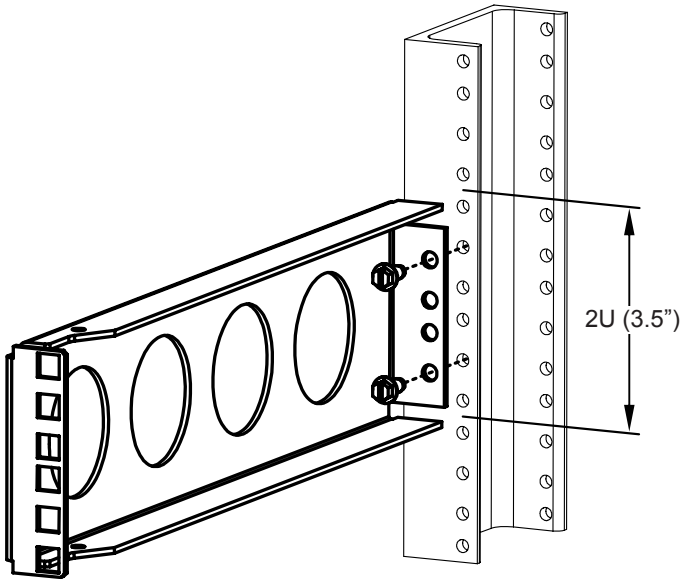

# Installation Instructions

**Step 3.** Screw (4) brackets to the rack using (2) bolts for each bracket: Ensure the bolts attach the bracket tightly to the rack.

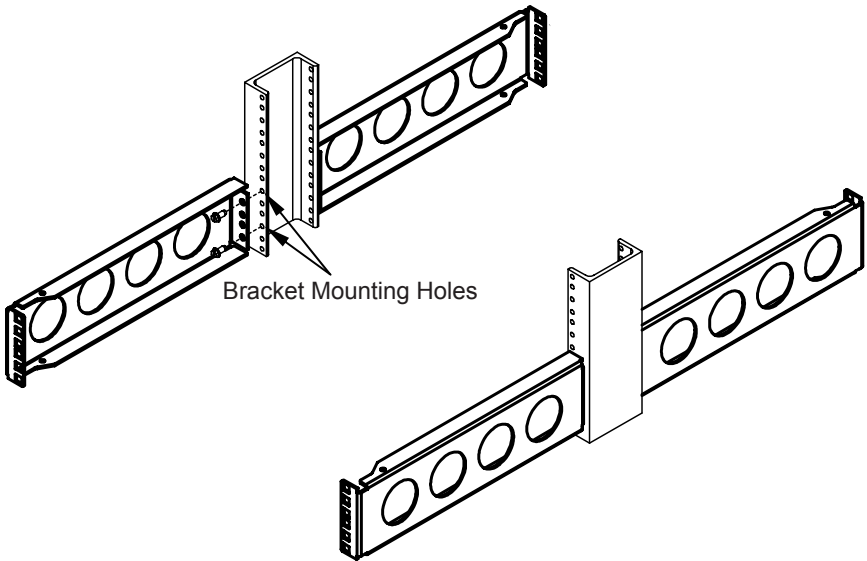

**Step 4.** Attach Front of Rails: Mount front of rails using RapidRail configuration as shown. The Blue button should be located in the bottom hole (see diagram below).

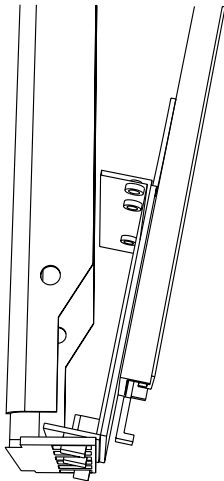

Hold Front of RapidRail at angle as shown and put hooks through holes. Then lower hooks and turn rail as shown on right.

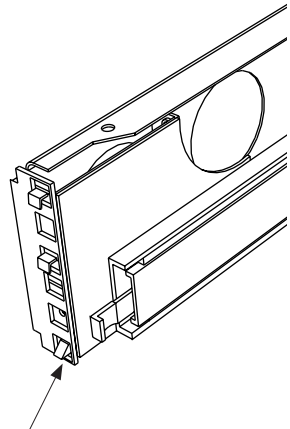

2U Slide with  
"Blue Button" Here

## Installation Instructions

---

**Step 5. Attach Rear of Rail:** Mount rear of rails using VersaRail configuration as shown below.

**Note:** PE 2950 rails can be configured for RapidRail (Hook Connection) or VersaRail (Screw Connection). For installation in the 2POST-2UKIT-2950 rear of rail must be set for VersaRail and front of rail must be set for RapidRail.

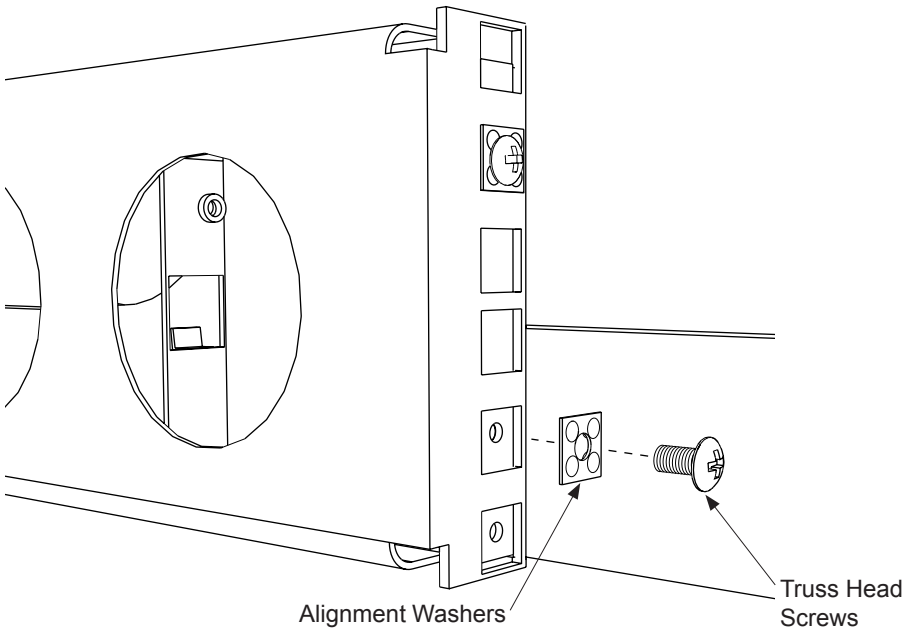

### Warranty Statement

Rackmount Solutions warrants our products against defects in material and workmanship for a period of one (1) year from the date of purchase. Rackmount Solutions liability shall be limited to repairing or replacing, at our option, any defective product.